

DASH ASSY TURNTABLE

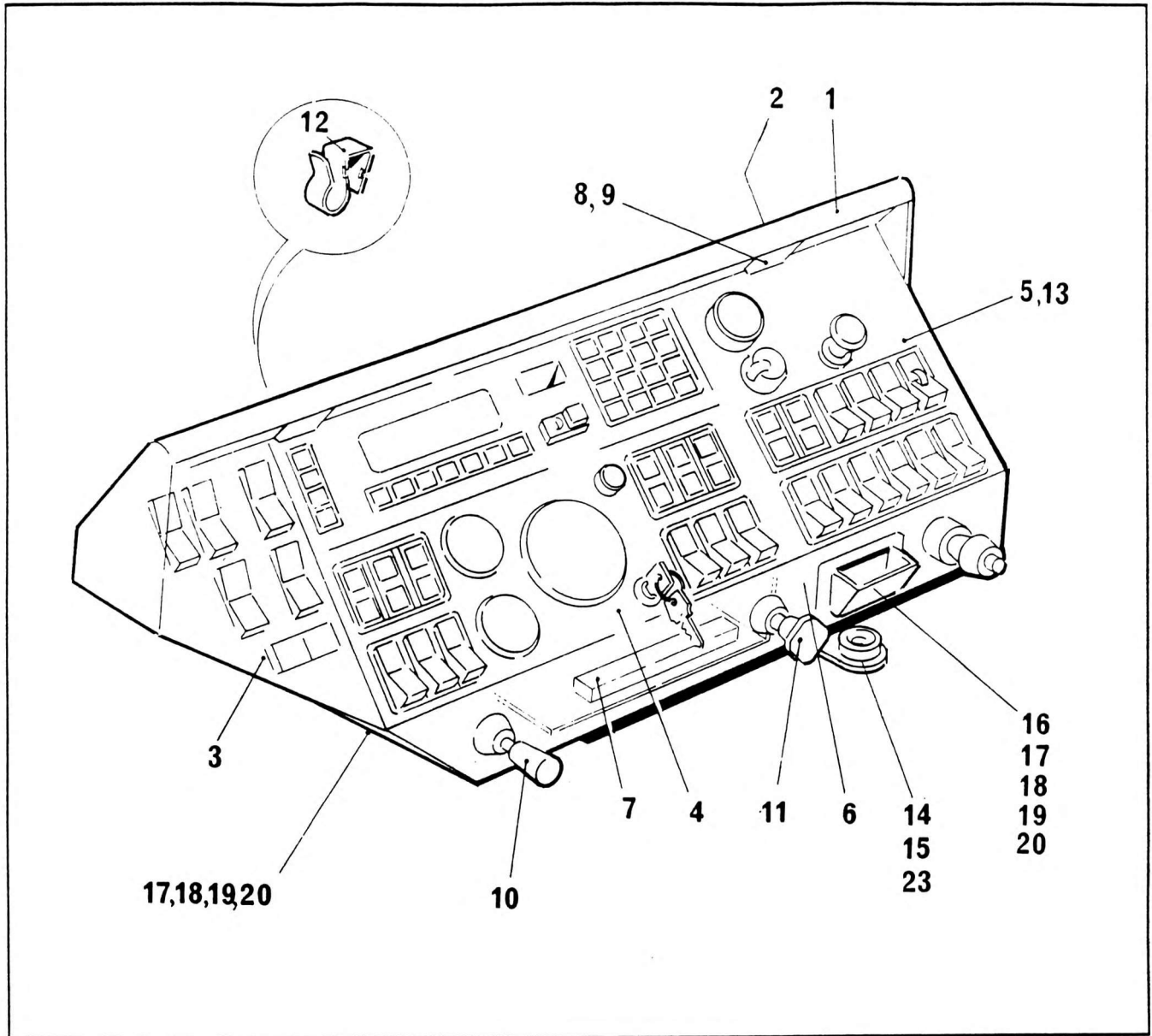

NO.	PART NO.	QTY.	DESCRIPTION	NO.	PART NO.	QTY.	DESCRIPTION
1	6-547-990087	1	Housing Dashpanel	17	7-661-130003	17	M5 Nut
2	6-535-990143	1	Cover Assy Dashpanel	18	7-951-130014	31	Washer M5
			Incl. Items 101-102	19	7-951-130210	17	Spring Washer M5
3 +	6-978-990645	1	Dash Assy LH	20	7-121-130800	3	Screw M5 x 12 Long
4 +	6-978-990646	1	Dash Assy Centre	21	7-126-131353	4	Screw M5 x 30 Long
5 +	6-978-990647	1	Dash Assy RH	22	7-126-131153	3	Screw M5 x 20 Long
6	7-679-990201	1	Dashpanel - Front	23	7-834-000190	1	Spring
7	6-978-990648	1	Relay Panel Assy	101	7-535-990045	1	Cover Dashpanel
8	7-581-990194	2	Interior Lamp	102	7-585-990017	2	Lock
9	7-581-990124	2	Bulb 24-5w				
10	6-872-990041	1	Switch Rear Steer				
11	7-926-000199	1	Hand Control Valve				
12	8384246	2	Clip				
13	7-786-990061	19	Screw 8 x 20				
14	7-486-001651	1	Level				
15	7-111-040410	3	Mach. Screw				
16	7-348-990005	1	Ash Tray				

6-978-990644
Issue No. 05